

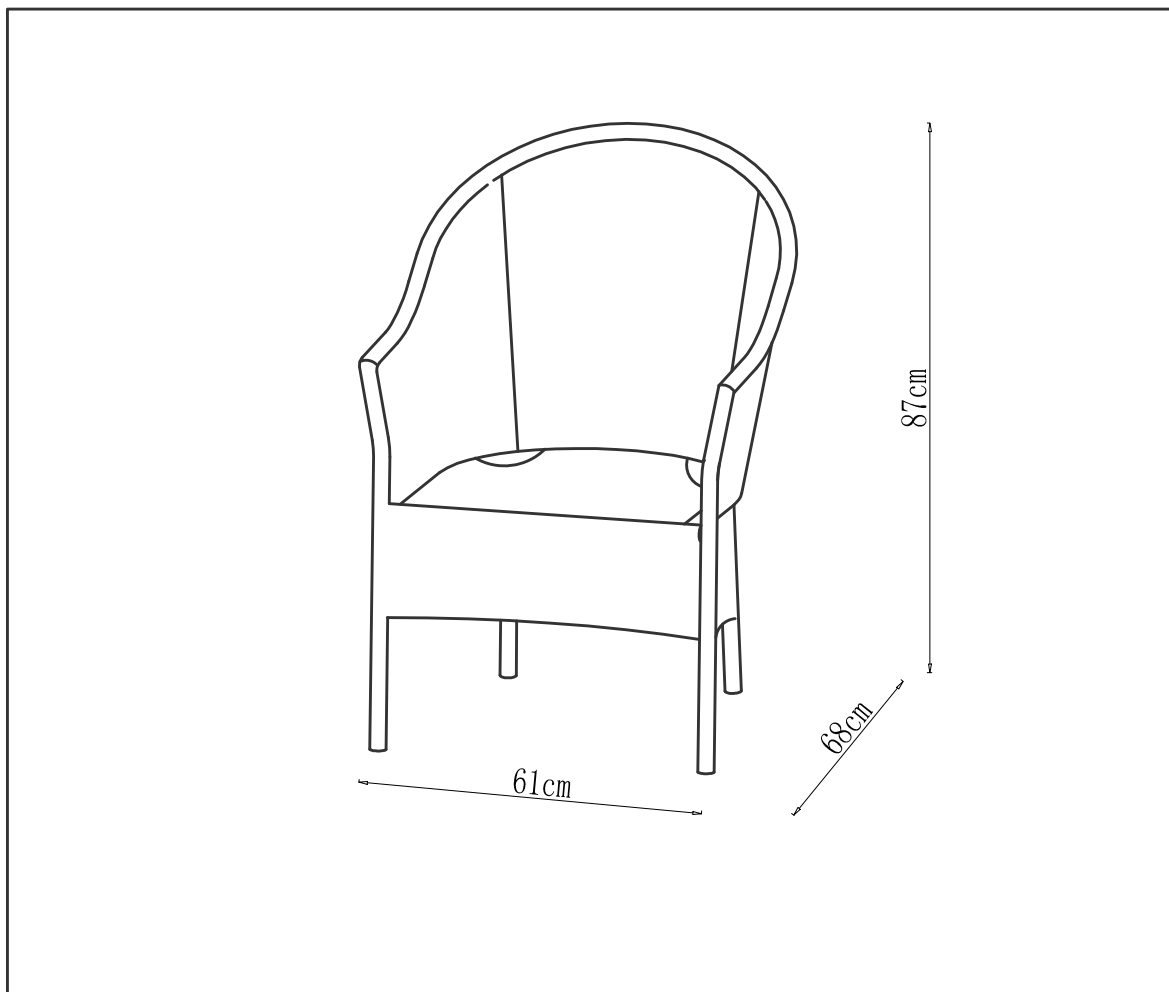

ASSEMBLY INSTRUCTION
JULIA 3PCE BALCONY SETTING
ITEM CODE - 65979

Imported by Amart Furniture Pty Ltd, Qld, Brisbane Australia .
For any assistance with assembly or for missing parts please phone
Amart Furniture , Customer Service Freecall 1800 351 084



Imported by Amart Furniture Pty Ltd, Qld, Brisbane Australia .
For any assistance with assembly or for missing parts please phone
Amart Furniture, Customer Service Freecall 1800 351 084

PRE-ASSEMBLY PREPARATION

Before you start:

1. Choose a clean, level, spacious assembly area. Avoid hard surfaces that may damage the product.
2. Take care when lifting. Product should be assembled as near as possible to the point of use.
3. Ensure that you have all required contents for complete assembly.
4. Always read the assembly instructions carefully before beginning assembly.
5. Keep all hardware parts and packaging out of reach of small children.
6. Do not over tighten the screws and bolts as this may damage the threads.

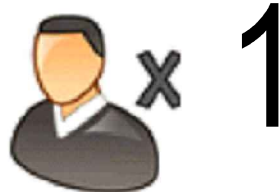
	
ALLOW 2 MINUTES	PEOPLE REQUIRED
ADDITIONAL TOOLS REQUIRED	

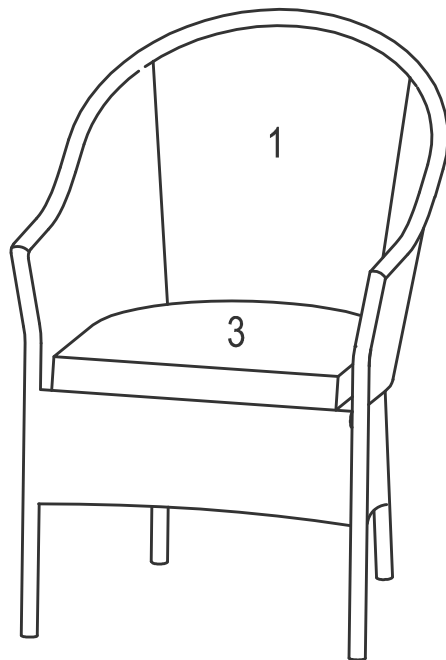

PARTS LIST

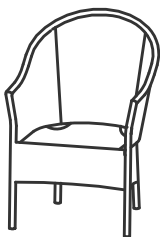
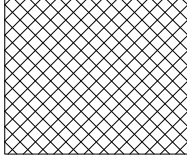
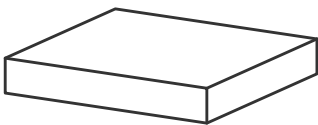

1 Single chair 	2 Non-slip mat  2PCS
	3 Cushion  2PCS

Step 1:

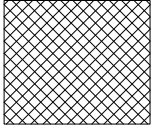
ITEMS REQUIRED

1. Single chair 1PC 	2. Non-slip mat 1PC 	3. Cushion 1PC 
--	--	--

- Put the non-slip mat (2) under the cushion (3) .

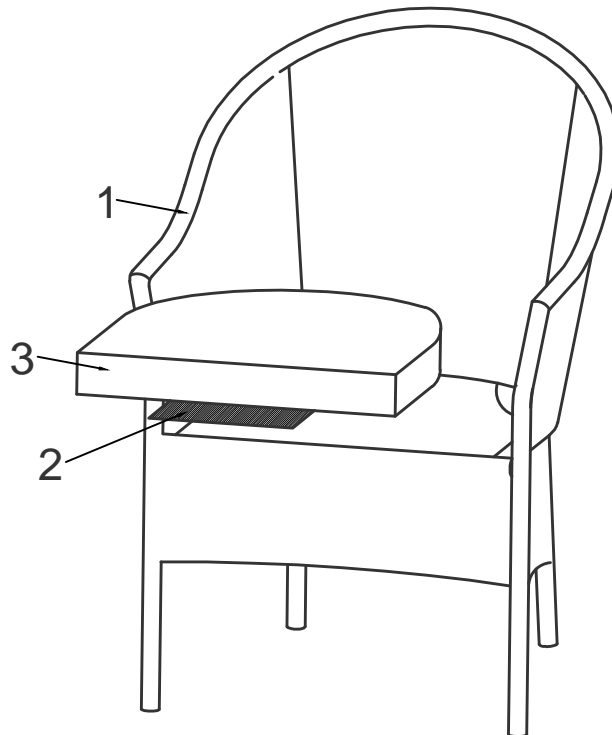

ASSEMBLY IS COMPLETE

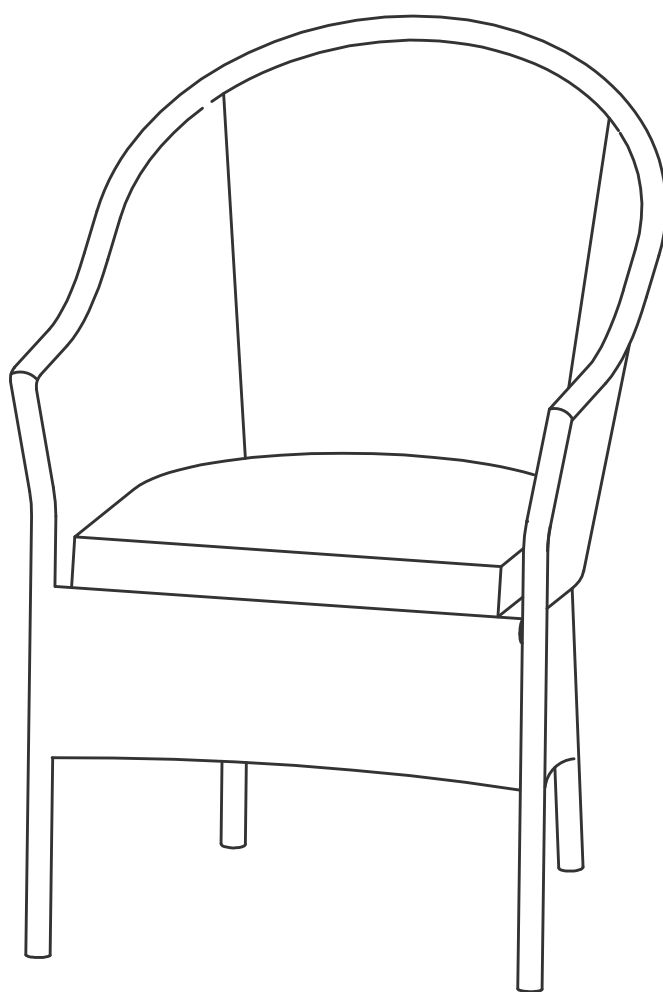



ASSEMBLY INSTRUCTION
JULIA 3PCE BALCONY SETTING
ITEM CODE - 65979

Imported by Amart Furniture Pty Ltd, Qld, Brisbane Australia .
For any assistance with assembly or for missing parts please phone
Amart Furniture , Customer Service Freecall 1800 351 084

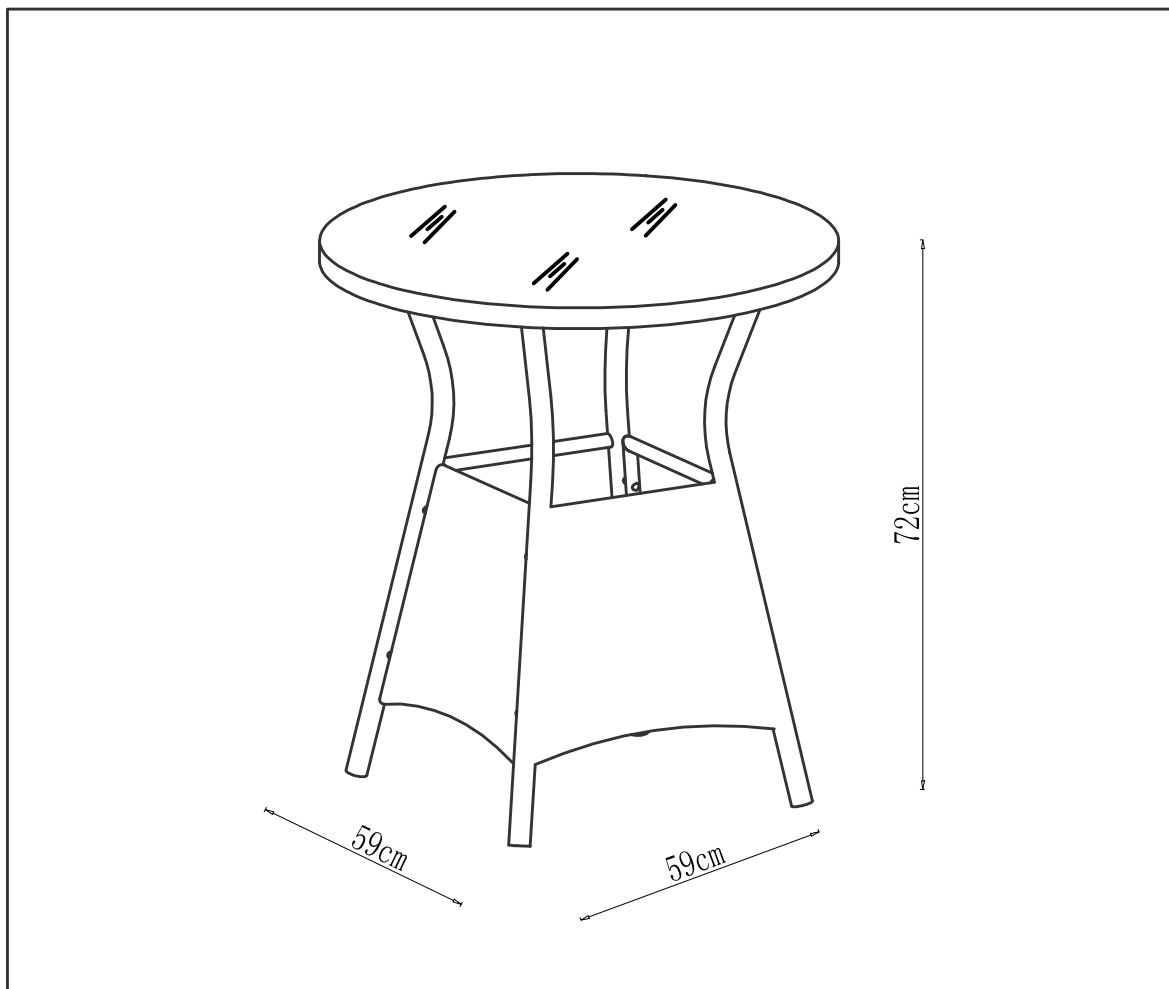

Imported by Amart Furniture Pty Ltd, Qld, Brisbane Australia .
For any assistance with assembly or for missing parts please phone
Amart Furniture, Customer Service Freecall 1800 351 084

PRE-ASSEMBLY PREPARATION



Before you start:

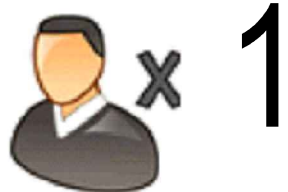

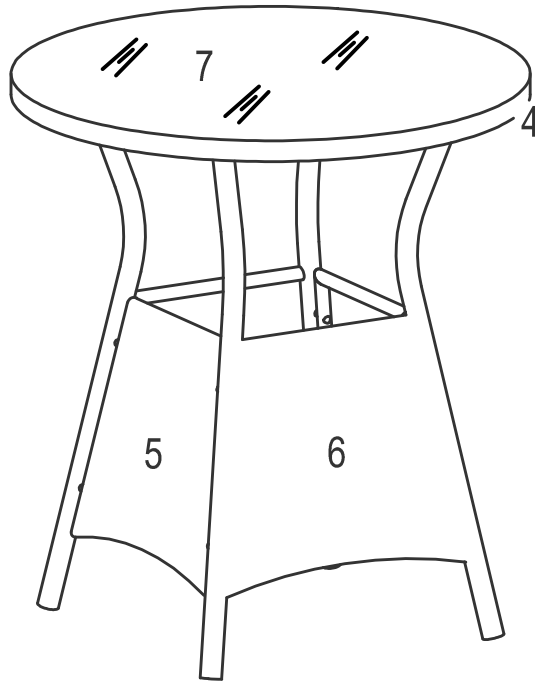

1. Choose a clean, level, spacious assembly area. Avoid hard surfaces that may damage the product.
2. Take care when lifting. Product should be assembled as near as possible to the point of use.
3. Ensure that you have all required contents for complete assembly.
4. Always read the assembly instructions carefully before beginning assembly.
5. Keep all hardware parts and packaging out of reach of small children.
6. Do not over tighten the screws and bolts as this may damage the threads.

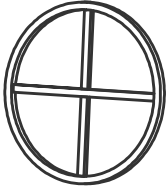
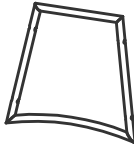
	
ALLOW 2 MINUTES	PEOPLE REQUIRED
ADDITIONAL TOOLS REQUIRED	

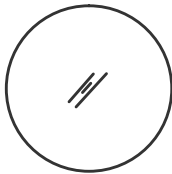



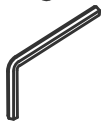

PARTS LIST



4	Table Top		1PC	5	Fixed link		2PCS
6	Legs		2PCS	7	Glass		1PC

A.	Bolt		M6*30*8PCS	B.	Bolt		M6*15*4PCS	C.	Hexagon Key		M6*1PC	D.	Shim		M6*12PCS
E.	Screw cap		M6*12PCS												

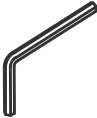

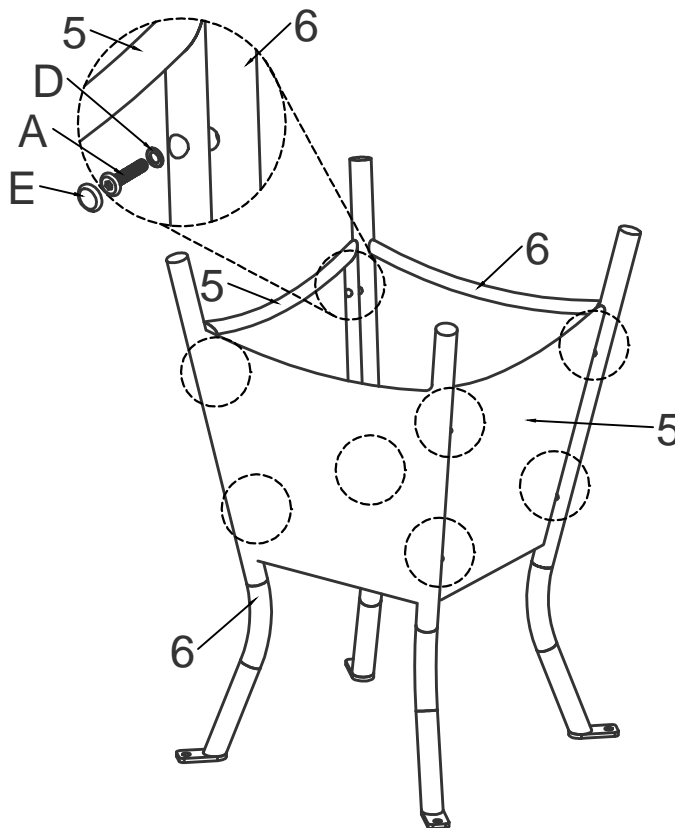

Step 1:

5. Fixed link 2PCS 	6. Legs 2PCS 		
A. Bolt  M6*30*8PCS	D. Shim  M6*8PCS	C. Hexagon Key  M6*1PC	E. Screw cap  M6*8PCS

- Attach fixed link (5) to legs (6) using bolt (A) with shim (D) and Screw cap (E) .
- Tighten with hexagon key (C) ,be careful not to over tighten.

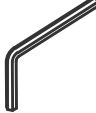

Step 2:

4. Table Top 1PC 			
B. Bolt  M6*15*4PCS	D. Shim  M6*4PCS	C. Hexagon Key  M6*1PC	E. Screw cap  M6*4PCS

- Attach table top (4) to legs (6) using bolt (B) with shim (D) and Screw cap (E) .
- Tighten with hexagon key (C) ,lock all the screws at the end.

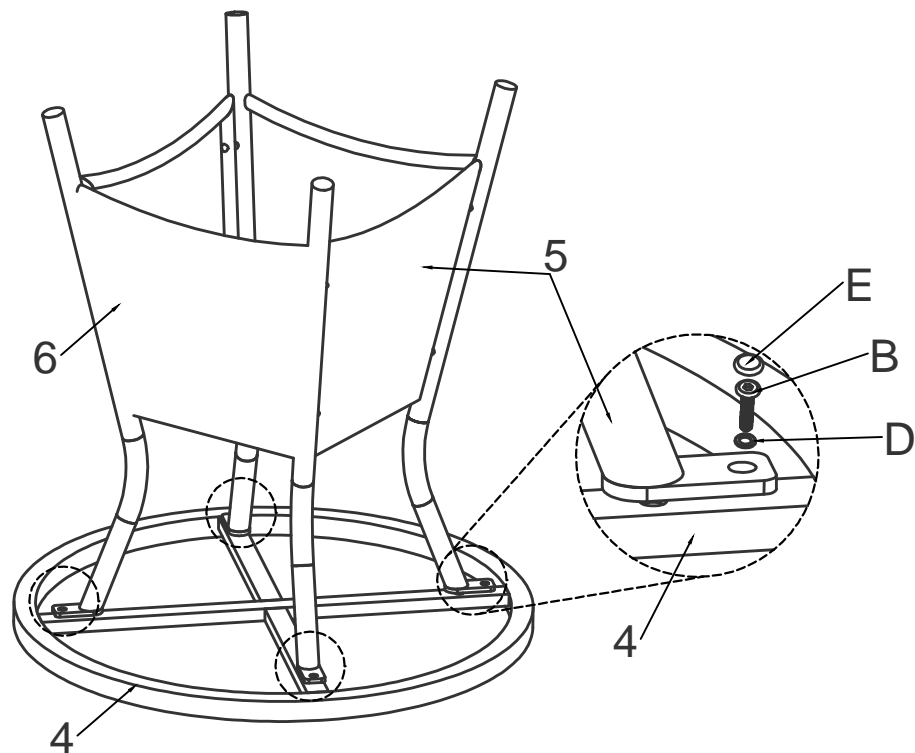

Step 3:

ITEMS REQUIRED

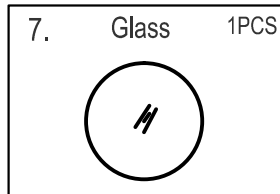

- Turn over the table frame.
- Place glass (7) on the top of the table.
- Glass is secured on the table with suckers.

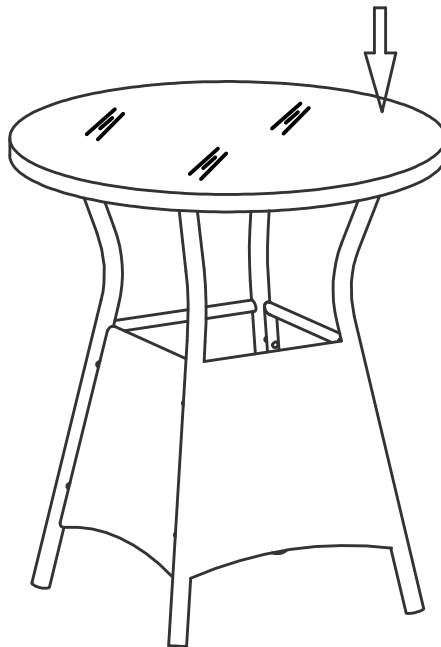

ASSEMBLY IS COMPLETE

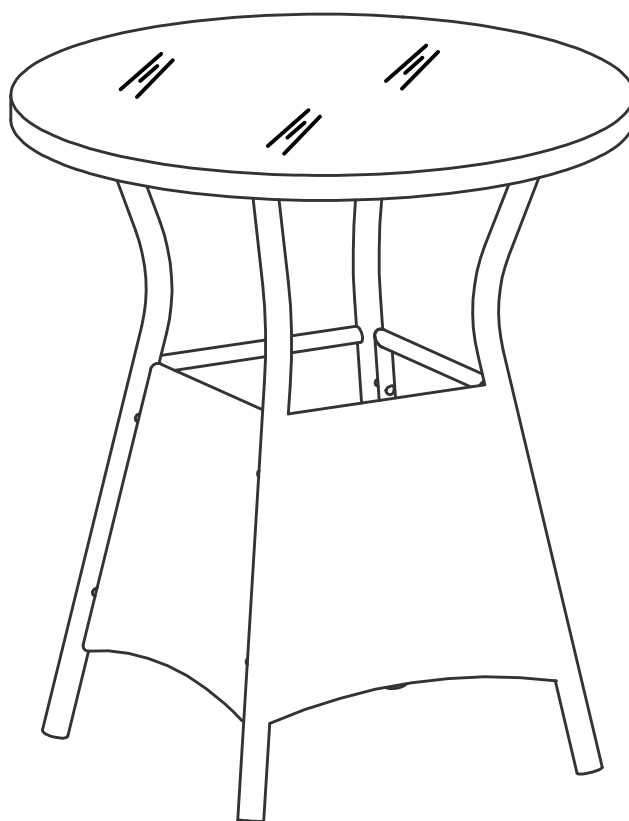

Care and maintenance



Cushions

- Direct exposure to the Sun's harmful UV rays is likely to cause rapid colour fading to fabrics. For best results we recommend avoiding exposure to direct sunlight
- To ensure product longevity it is recommended outdoor products are not left permanently exposed to the elements
- Spot clean using mild detergent and damp cloth. Dry flat in shade
- Do not unzip
- Do not put in washing machine
- Do not tumble dry
- Do not bleach
- Do not dry clean
- Cool iron only

Metal

- Item is designed for use outdoors. However we do not recommend leaving this product outside when not in use. To preserve the life of this item, avoid prolonged exposure to the elements & store inside/under cover or use an outdoor cover.
- DO NOT allow the furniture to be left in the rain or left wet for extended periods of time.
- Wipe furniture Dry immediately after it becoming wet.
- DO NOT clean your furniture down with any harsh solvents, abrasives or chemicals.
- To remove dirt and grime, simply rinse with fresh water or periodically clean using a sponge and mild detergent solution as required

Wicker

- Regular vacuuming and dusting of items is recommended.
- If weave on wicker becomes lacerated/damaged, do not pull on it as this may cause unravelling.
- Prolonged exposure to the elements may cause colour fading.
- To extend the life of your product the use of an Amart approved Outdoor Furniture Cover is highly recommended. Please contact store of purchase for further details.

Glass

- If the glass is chipped or broken, stop using the product and consult place of purchase .
- Do not drop, drag or strike glass .
- Do not sit or stand upon the glass surface .
- Do not place very hot or cold items on the glass surface unless adequately thick table mats are used to prevent such items coming in contact with the glass .
- Do not place heavy objects on glass .
- Avoid scratching the glass or using as a chopping surface .
- Do not strike the glass with hard or pointed items .
- When cleaning the glass panels use a damp cloth with washing up liquid or soft soap if necessary. Do not use washing powders or any other substances containing abrasives since these may scratch the glass.